

# 3-Way Globe Valve



---

## Contents

<b>1. General</b> .....	<b>2</b>
1.1 Introduction to Valves.....	2
1.2 Valve Control.....	3
<b>2. Storage</b> .....	<b>4</b>
<b>3. Installation</b> .....	<b>4</b>
<b>4. Operation</b> .....	<b>10</b>
4.1 Inspections before Operation.....	10
<b>5. Maintenance and Repair</b> .....	<b>11</b>
5.1 General .....	12
5.2 Disassembly and Assembly of Valve Body and Actuator.....	12
5.2.1 Disassembly .....	12
5.2.2 Valve Assembly.....	134
5.3 Disassembly and Assembly of Actuator.....	14
5.4 Disassembly and Assembly of Body .....	15
5.4.1 Disassembly .....	15
5.4.2 Assembly .....	16
<b>6. Preventive Maintenance and Troubleshooting</b> .....	<b>19</b>
6.1 Troubleshooting.....	19

## 1. General

### 1.1 Introduction to Valves

- A) The 3-way globe valve has been designed for the requirements and applications of piping. As flow rate is effectively controlled, it has less cavitation, noise, corrosion, or vibration relatively.
- B) The most important feature of the Komoto 3-way globe valve is its body that has been manufactured in appropriate sizes to meet the requirements of piping. It consists of a body that includes a cage to control flow speed, a seat ring, a bonnet, and an actuator.
- C) The Komoto 3-way globe valve is designed for easy maintenance with a quick change trim that does not require the use of screws or welding.
- D) The Komoto 3-way globe valve trim boasts a long life span and has few faults. To use the system to its full life span, you should install it correctly according to the manual and maintain it according to the prescribed procedures while using it.

#### **☀ Recommendations**

Engineer who has professional assembly capabilities are required to maintain 3-way globe valves. Therefore, it is more economical to request repairs of the valves to Komoto. As the valves repaired by Komoto are thoroughly tested and warranted, you are recommended to entrust Komoto with repairs.

**To avoid possible injury to personnel or damage to valve parts, WARNING and CAUTION notes must be strictly followed. Modifying this product, substituting non-factory parts or using maintenance procedures other than outlined could drastically affect performance, be hazardous to personnel and equipment and may void existing warranties.**

### 1.2 Valve Structure

- A) The 3-way globe valve is largely classified into single contoured plug type and cage plug type. <See FIG. 1-1, 1-2, 5-4>

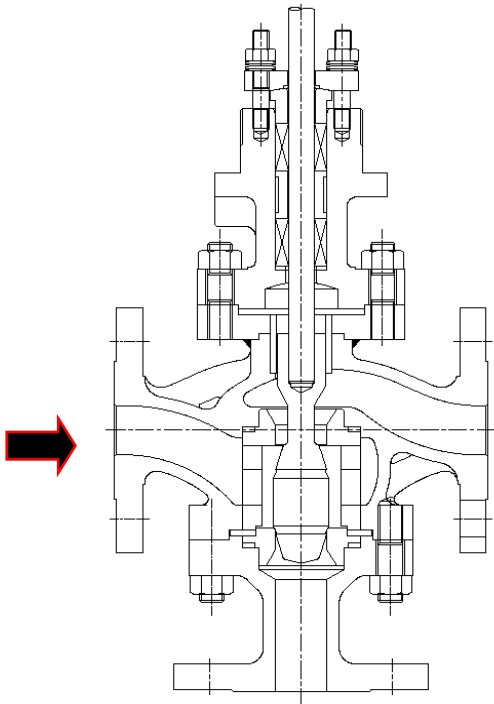

<FIG. 1-1> Divert Type

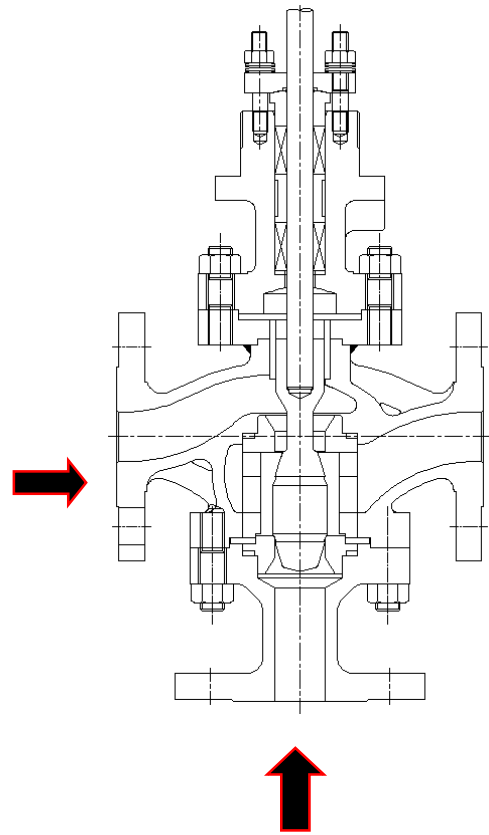

<FIG. 1-2> Mixing Type

## 2. Storage

- A) Do not throw, drop, trip or drag control valves when transporting them.
  
- B) Keep all parts of the control valve in a well-ventilated place protected from fire, rain and wind.  
Store the valve at a temperature between - 29°C (-20°F) and 48°C (120°F).  
The storage area must be protected from flooding.
  
- C) Operate the elastomer (rubber) of the pneumatic actuator at least once every six months to prevent their functional degeneration. Operate it to the full stroke even under general operation conditions at least three times a month.
  
- D) Do not remove the flange cap attached to the flange surface to prevent foreign substances from penetrating into the system until valves are installed on the line.

## 3. Installation

Like any other valves, the Komoto control valve must be installed carefully at first according to the following cautions to use it for many years without malfunction.

### **Cautions**

- ① When moving control valves, you should handle them carefully so that the components and air piping will not be damaged. Otherwise, the electronic and electric parts such as solenoid valve, positioner, and limit switch may get damaged or the valve travel may change.
  - ② Be careful not to damage the sealing surface of valve flange.
  - ③ Apply thermal insulation as needed, but do not apply thermal insulation to the cooling fin and extensions.
- 
- A) Remove the flange cap and check whether there are any foreign substances in the body. If you find foreign substances, remove them before starting installation.
  - B) As cast steel products are processed with rust preventive oil before shipping to prevent corrosion, remove the rust preventive oil from the pipes before installing them on the line.
  - C) Blow off all foreign substances including welding chips in the pipes before starting installation.

**- Warning -**

To prevent damages to plugs and seats, you must blow out (flashing) foreign substances such as weld beads, scales and chips from the pipeline according to the prescriptions before installing the globe valve.

- D) Install valves in the direction of arrow marked on the body.
- E) When assembling the flange-type valve, you should use a specified gasket, and install it in parallel with the other flange. Also, you are recommended to fasten the bolts in several parts in a balanced manner sequentially in diagonal direction. <See FIG. 3-1>

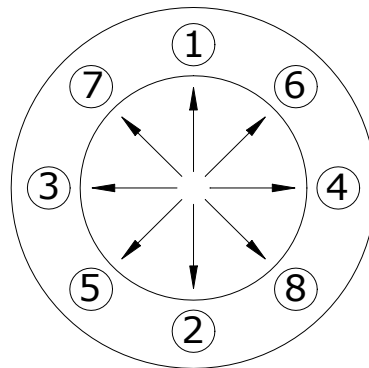

<FIG. 3-1> Procedure for Fastening Flange Bolts

※ Correct Transport Method

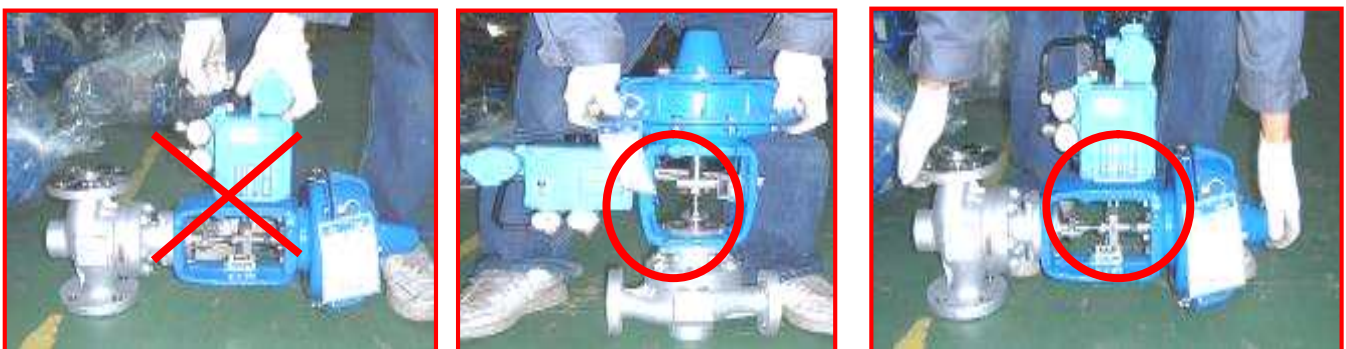

- F) Install the valve at right angle to the ground as much as possible. If this is impossible, attach a support to the valve before installing it. <See FIG. 3-2, 3-3>

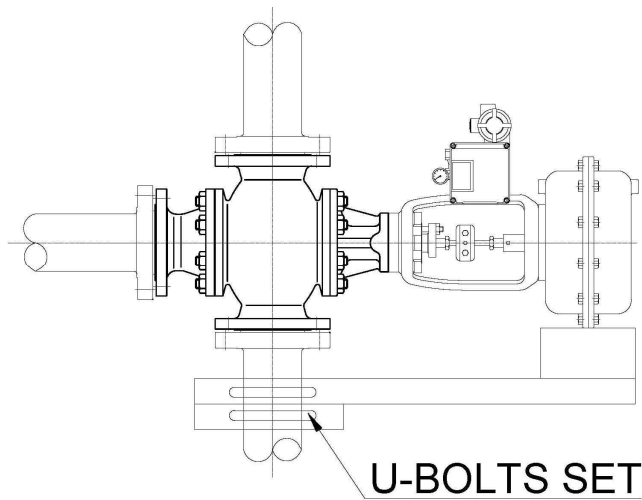

<FIG. 3-2> Installing Support

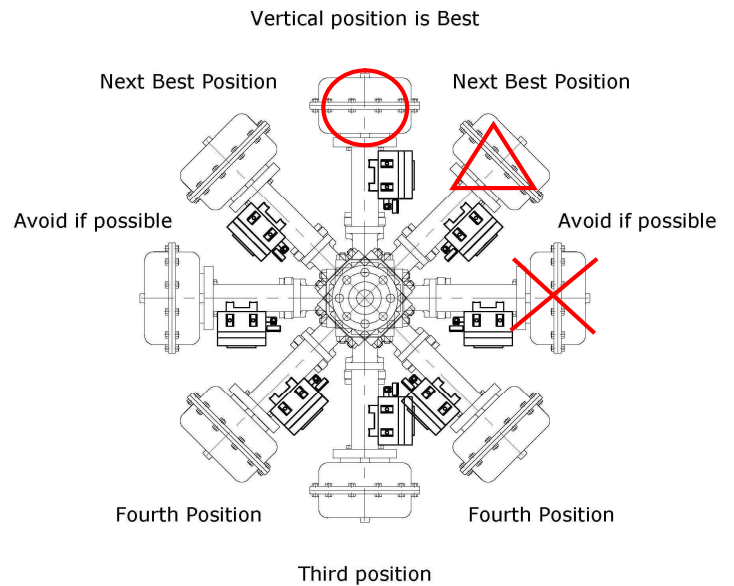

<FIG. 3-3> Installation Location of Actuator

## **☀ Cautions**

- ① Avoid horizontal piping if possible because it may adversely affect the function and performance of valves during operation.
- ▶ The valve trim part (port) may be deflected downward and affect the stability of operation.

- G) A minimum space is required for maintenance of the valve installation area. <FIG. 3-4> In addition, a space for manual operation is required if a manual hand wheel has been installed.

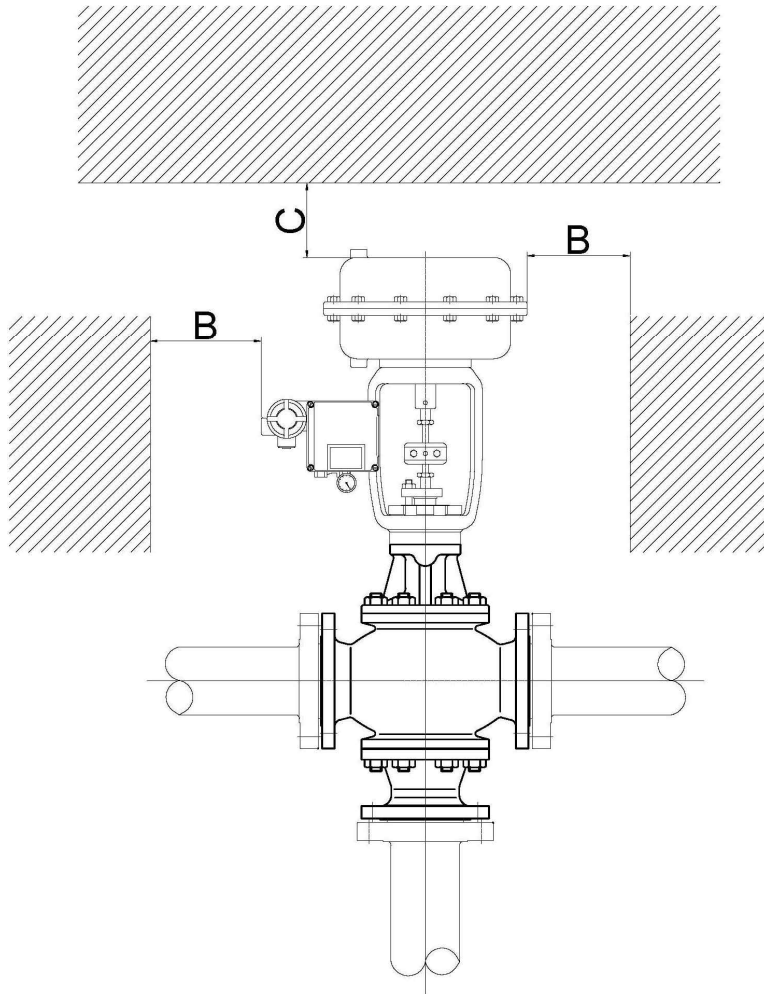

<FIG. 3-4> Space required for control valve installation

☞ B: Face-to-face distance and minimum distance from and obstacles (Approx. 30 cm)

C: Space for removing the actuator (Approx. 40 cm)

H) Install a bypass line for valve maintenance. <See FIG. 3-5>



**☀ Note**

When the control valve has a problem, you may have to close the block valve and open the bypass valve to adjust flow. Therefore, use a control valve that has the feature to adjust flow by opening the bypass valve. Moreover, it is ideal to choose the same flow characteristics and size as those of control control valve. FIG. 3-6 shows an example of ideal control valve installation recommended by Komoto.

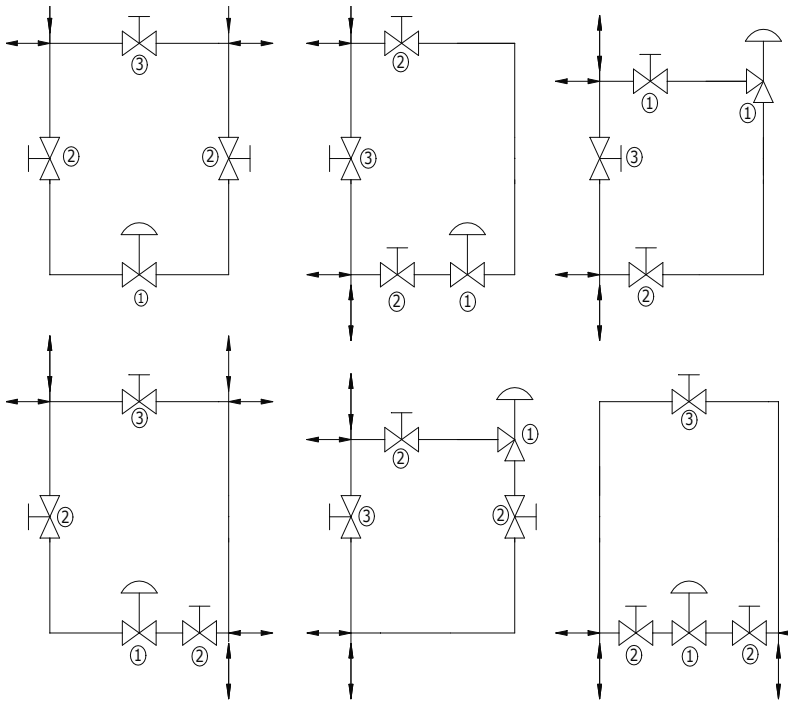

<FIG. 3-5> Example of Control Control Valve Installation

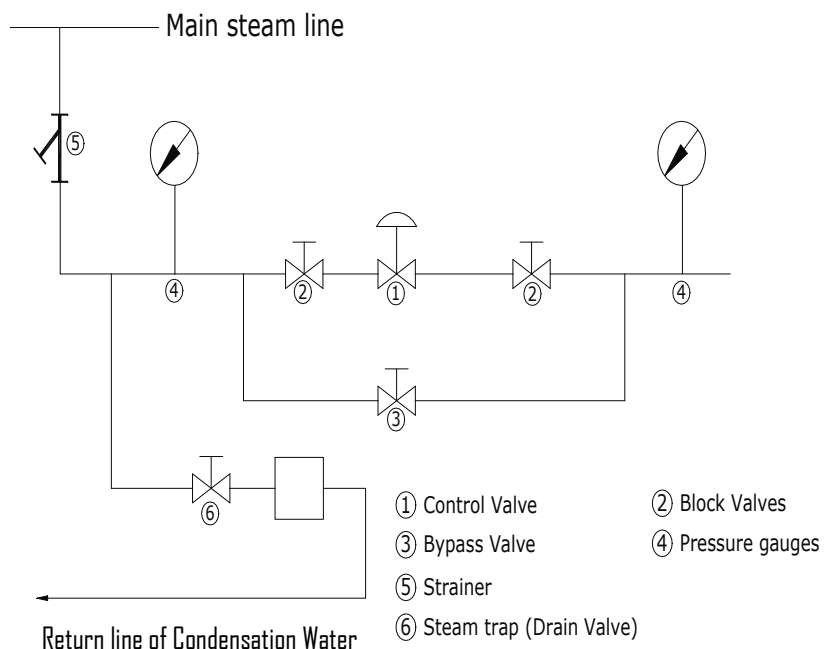

<FIG. 3-6> Example of Control Valve Installation Recommended by Komoto

**☀ Note**

To maintain a constant pressure at the entrance for all tracks of the valve, the straight pipe length at the valve entrance must be at least 10 to 20 times the pipe diameter. For the fluid to maintain the specified pressure after passing the valve and to prevent noise or vibration by turbulent flow, the straight pipe length at the valve exit must be at least 3 to 5 times the pipe diameter. Straight piping at the entrance and exit allows the preservation of accurate operation status by enabling accurate measurement of the pressure at the entrance and exit. <See FIG 3-7>

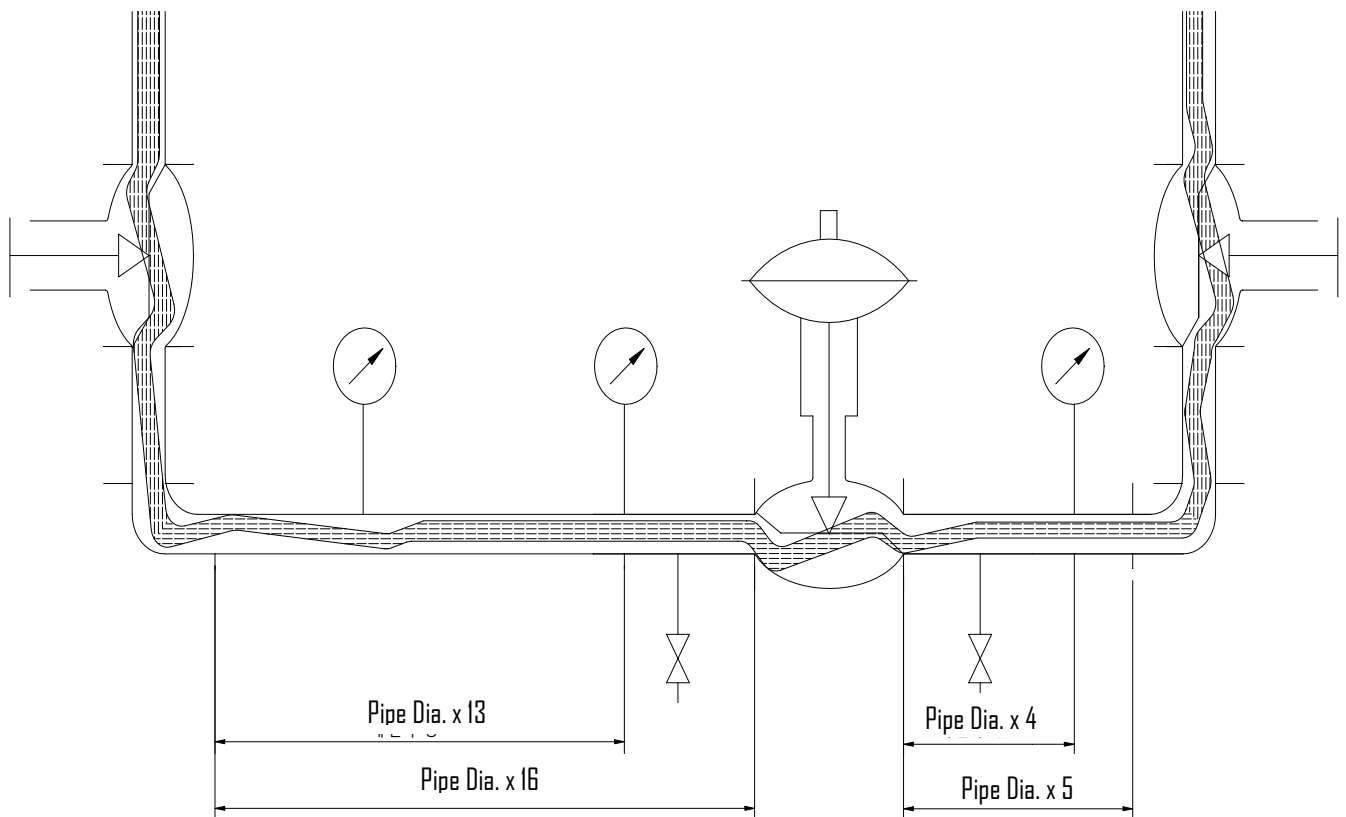

<FIG. 3-7> Minimum straight pipe length for valve performance and pressure measurement

## 4. Operation

### 4.1 Inspections before Operation

- ① Check whether there is any leak from all connections including the air pipe connections.
- ② To check whether there is any leak from gland packing and gaskets, apply a pressure to the pipeline. If any leak is detected, remove pressure from the pipeline and fasten the gland flange nut.
- ③ Check whether there are any loose nuts (clamps) at the valve stem and the spindle of the actuator.
- ④ Check whether there is any short circuit in the electric signal system.
- ⑤ Check whether the attached manual hand wheel is at the Neutral position.
- ⑥ Check whether the system operates accurately and flexibly according to the signals from the controller.
- ⑦ When raising the temperature or pressure, do it slowly. Never raise the temperature or pressure quickly.
- ⑧ Check whether the air pressure required for valve operation is accurately set.  
(Diaphragm Actuator: 4.0 kg/cm<sup>2</sup> -> Specified in the name plate)
- ⑨ Electrical devices such as positioner, limit S/W, solenoid V/V are attached to an control valve. Even if the manufacturer has adjusted them, the tubing may be bent or the valve stem's position becomes incorrect due to a shock during transportation or careless handling during assembly. Therefore, it is recommended to readjust the valve during the test run.

#### - Warning -

- ❶ Remove air pressure from the actuator before using the manual hand wheel. If you use the hand wheel without removing air pressure, it may not work normally and its weak part may get damaged by overstrain.
- ❷ If the manual hand wheel is not at the neutral position during control operation, it may not work normally and its weak part may get damaged.
- ❸ If you use a pressure higher than the specified pressure on the name plate, the rubber and O-rings of the actuator may be damaged and cause operation problems.

## 5. Maintenance and Repair

### \* Regular Inspection

Repair and inspect as described below. If any malfunction occurs, take appropriate measures according to the preventive maintenance procedures and troubleshooting in Chapter 6. Also, disassemble and inspect the system during the regular overhaul period, and replace parts if necessary.

### ☀ Recommendations

- ❶ The life span of the valve can increase if you replace parts according to their replacement cycles. Refer to the Part Replacement Cycle Sheet shown below.

Part Replacement Cycle Sheet		
Item Name	Replacement Cycle	Others
Diaphragm Rubber	5 years	
Diaphragm O-ring	3 years	
Packing	2 years	
Gasket	2 years	
Port & Seat		Replace after inspection according to the fluid conditions and used environment.

### \* Irregular Inspections

- A) Are there abnormal noise, vibration or hunting?
- B) Does the fluid leak from the valve?
- C) Are there any loose bolts and nuts?

u

## 5.1 General

### - Warning -

1. To prevent human injuries and damages to control system, close the block valve, remove instrument air and signals from the valve and open the bypass valve to switch over the pressure from the line to the bypass. Then slowly unfasten the bolts from the pipe until the internal pressure of the body is completely released and remove the valve before disassembling the actuator.
2. Keep hands, hair and clothing away from seat and port when operating valve. Failure to do so could cause serious injury.

- ♣ Prepare gland packing and gaskets (seat, bonnet) as required. (Do not reuse parts that have been used.)

## 5.2 Disassembly and Assembly of Valve Body and Actuator

### 5.2.1 Disassembly

#### ※ Note

- Mark important parts to assemble them to their original position during assembly.
- When disassembling for direct action, skip step ② and go to step ③.

#### ◆ Valve Disassembly Procedure <See FIG. 5-1>

Reverse Action: Disassemble in the sequence of ①→②→③→④→⑤→⑥. (Air Fail Close)

Direct Action: Disassemble in the sequence of ①→③→④→⑥. (Air Fail Open)

- ① Remove all accessories including positioner from actuator.
- ② Supply about 2.0kg/cm<sup>2</sup> of air to yoke actuator to open the valve about 50%.
- ③ Using a hexagonal wrench, unfasten the bolts from the clamp to remove it. <Fig 5-1-1>  
- Mark the assembly positions of the valve stem and spindle before removing them from the clamp.
- ④ Yoke Nut Assembly Form <Fig 5-1-2>

Turn counter clockwise the yoke nut connecting the actuator yoke and valve body to unfasten it and unfasten the set screws on the yoke.

Bolt Assembly Form <Fig 5-1-3>

Unfasten the bolts connecting actuator yoke and valve body.

⑤ Remove air of 2.0 kg/cm<sup>2</sup> from the actuator.

1

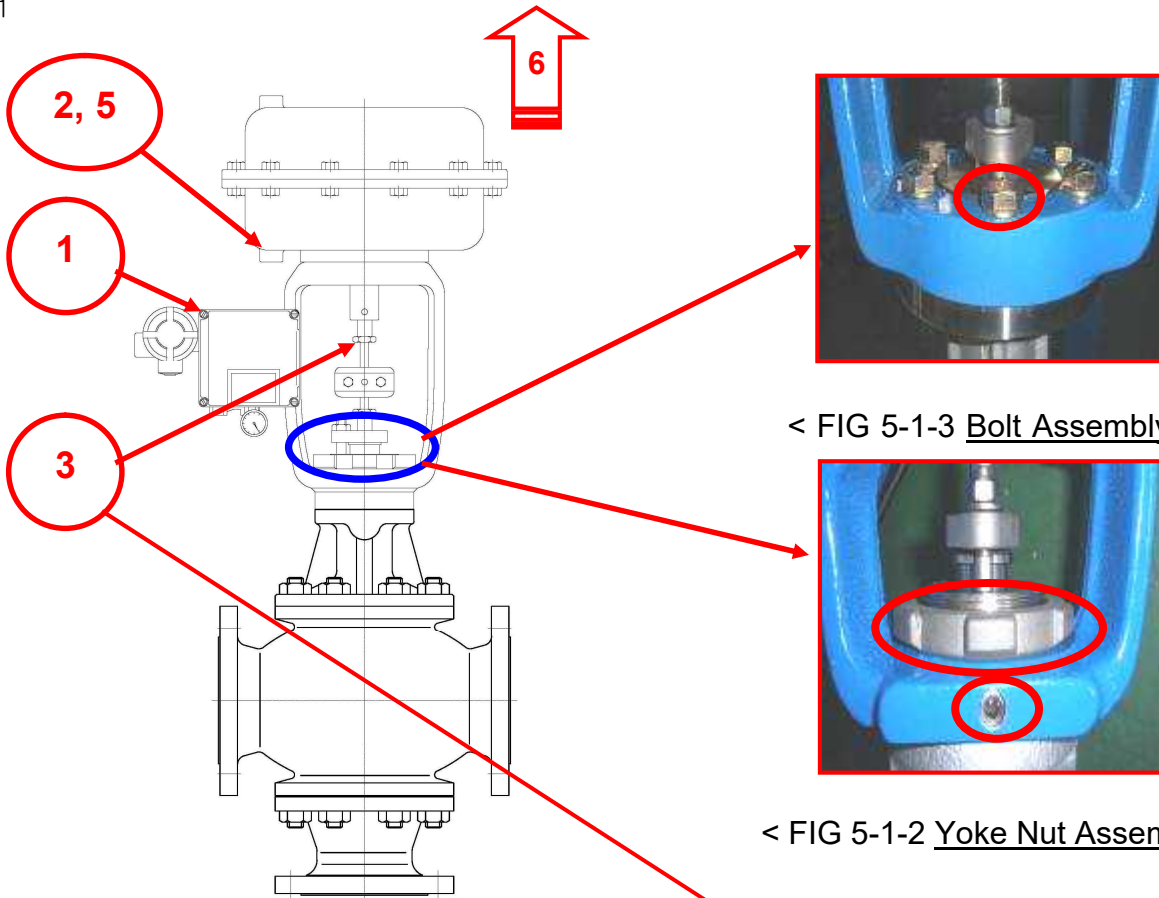

< 3-WAY GLOBE VALVE >



< FIG 5-1-3 Bolt Assembly Form

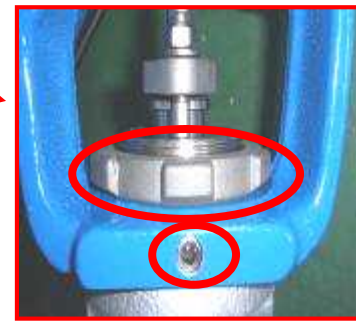

< FIG 5-1-2 Yoke Nut Assembly Form >

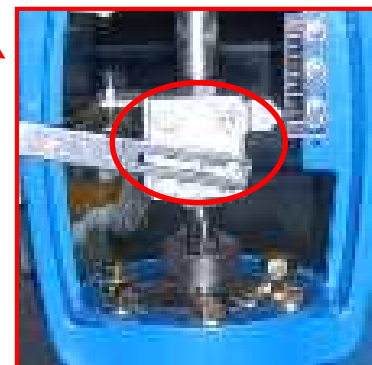

< FIG 5-1-1 Clamp >

< FIG. 5-1 > Picture of Disassembly Body and Actuator

## 5.2.2 Assembly

- ① Assemble in the reverse sequence of the disassembly.
- ② Assemble Actuator and Body
- ③ When fastening the actuator spindle and valve stem with a clamp, supply air of 4 kg/cm<sup>2</sup> to the actuator to remove the air pressure of about the valve stroke from the total stroke of the actuator. Then fix them and fasten the clamp.
- ④ Check the stroke of the valve. (Make sure that there is no leak from the seat.) - If the stroke is short, remove the clamp, adjust the stroke, and refasten the clamp.
- ⑤ Reconnect accessories including positioner. Then perform calibration again.

### **※ Note**

- A) A stroke refers to one cycle of complete opening and closing of the valve, and is not related to the end of travel. Adjustment is required so as that the maximum travel stroke can be reached without exceeding the required travel.
- B) The correct valve travel is printed on the name plate of the valve.

## 5.3 Disassembly and Assembly of Actuator

- ◆ Do not disassemble or assemble the actuator on your own at the site, but contact our technical department.

### **- Warning -**

The components of a spring return type actuator are pressed down by a spring. Take general safety measures and disassemble correctly. Otherwise, injuries and damages may result.

## 5.4 Disassembly and Assembly of Body

### 5.4.1 Disassembly

- ① As described in Section 5, Clause 5.2, remove the actuator from the valve while taking care not to damage accessories and pipes by the valve body components.
- ② Unfasten the hexagonal nut from the bonnet.
- ③ Unfasten the gland packing nut and remove the bonnet from the body while pushing down the valve stem.
- ④ Remove plug/seat, valve gaskets, other components from the body.
- ⑤ Remove packing from the bonnet using hook.
- ⑥ Clean each part and check them for any damage. Prepare available parts for future repair.

**- Warning -**

1. To replace packing, remove packing while taking care not to damage the internal surface of the packing box.
2. Do not over tighten packing. This can cause excessive packing wear and high shaft friction, which may impede shaft rotation.
3. Take special care not to damage the splined end of the stem during disassembly.

• Inspection after Disassembly

- i ) Are there any damages to the seat ring contact surface, plug, cage, stem, or guide?
- ii ) Are there any damages to the body sealing surface?
- iii ) Are there any damages to the gasket and gland packing?



### 5.4.2 Assembly

**※ Recommendations**

Be sure to inspect and replace worn out parts before reassembling them. You are recommended to always replace soft products such as gland packing and gasket before reassembling.

- 1) Assemble in the reverse sequence of the disassembly. <See FIG. 5-3, 5-4>
- 2) Place the bottom gasket (9) on the bottom flange (10).
- 3) Assemble the seat ring (6) over the bottom gasket (9). Assemble the bottom flange (10) to the body (1).
- 4) Place the seat gasket (5) on the body (1).
- 5) Place the seat ring (6) over the seat gasket (5).
- 6) Insert the port (7) into the body (1).
- 7) Mount the bonnet gasket (11) on top.
- 8) Place the bonnet (2) over the valve body and fasten the bonnet nut (4) temporarily.
- 9) Install the packing. <For packing placement, see FIG. 5-2>
- 10) Reassemble the valve to the actuator according to the procedure described in Section 5, Clause 5.2.
- 11) Check for leak of valve (ANSI / FCI 70-2 Standard)
- 12) Refasten the bonnet nut, when leak match allowance.

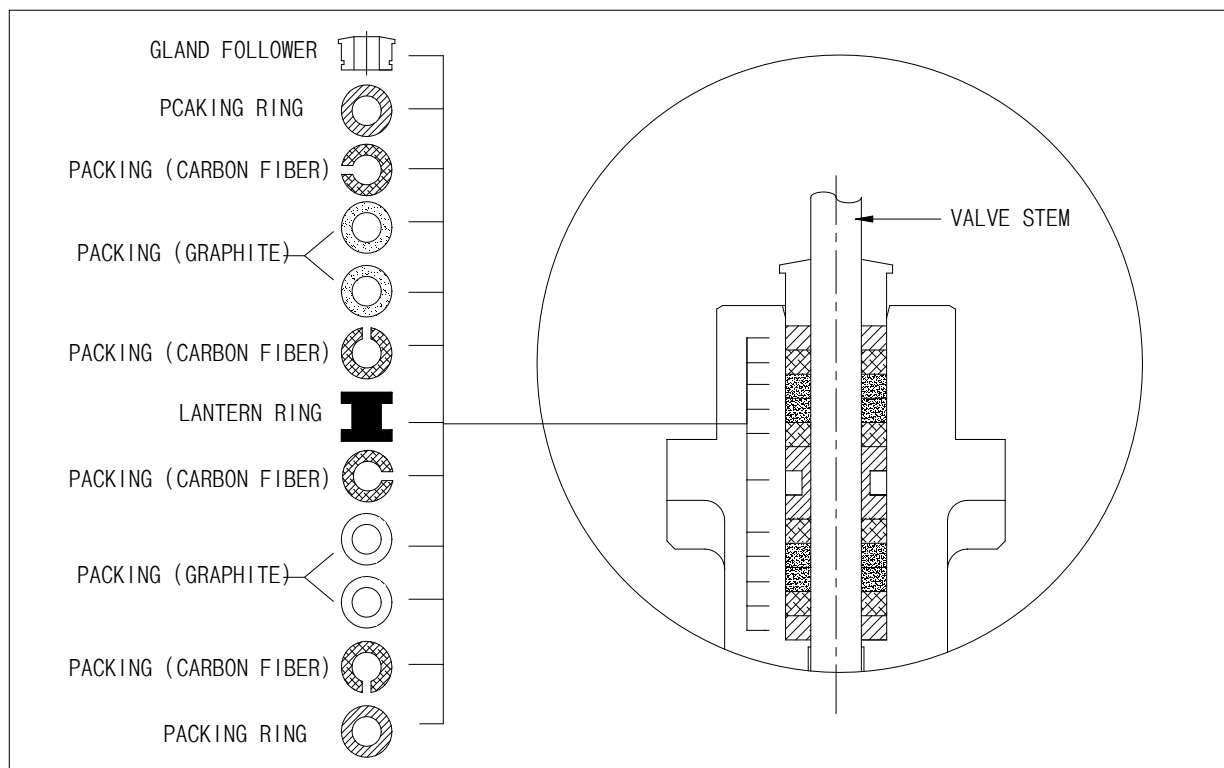

<FIG. 5-2> Placement of Packing

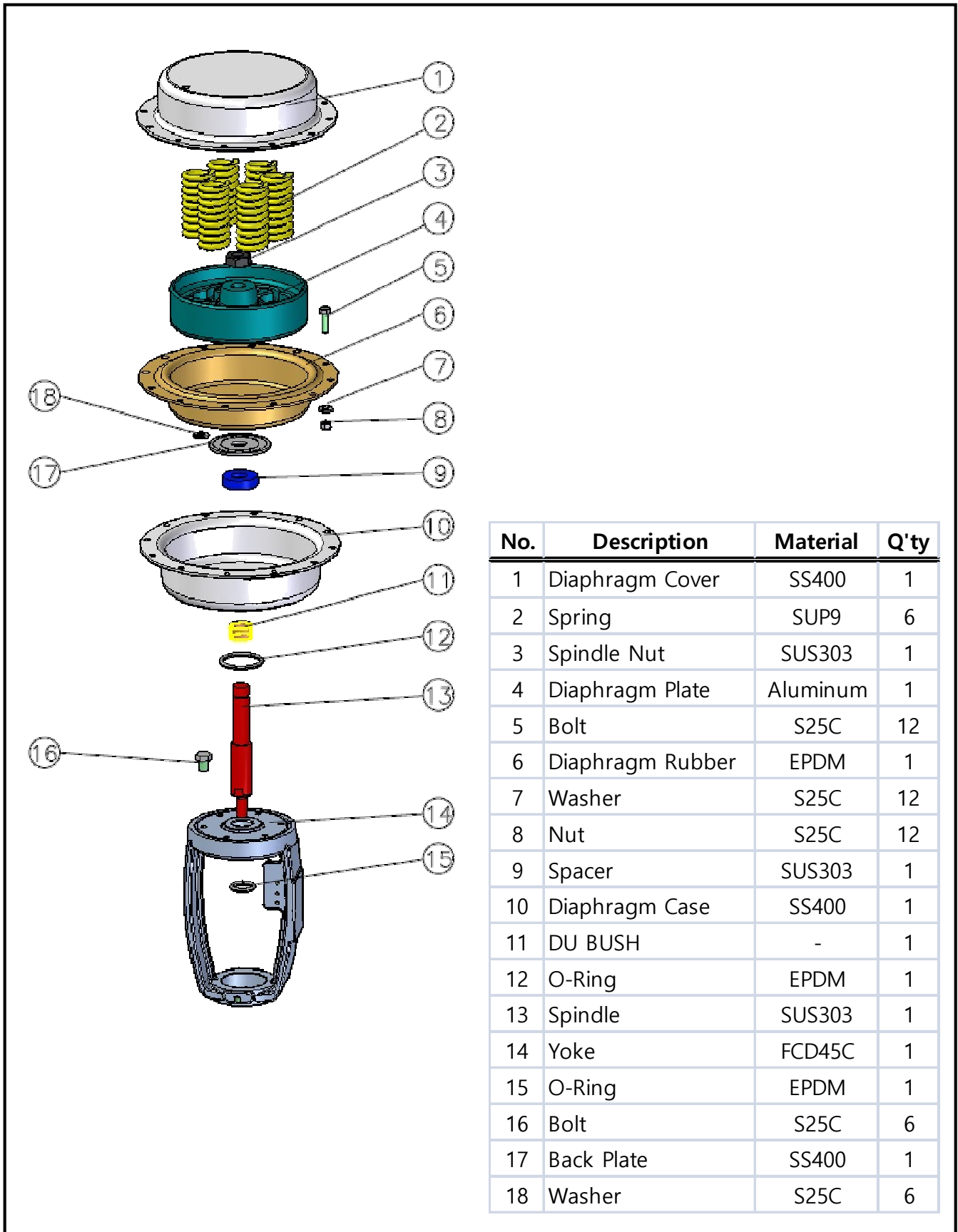

<FIG. 5-3> Actuator Disassembly and Assembly Diagram

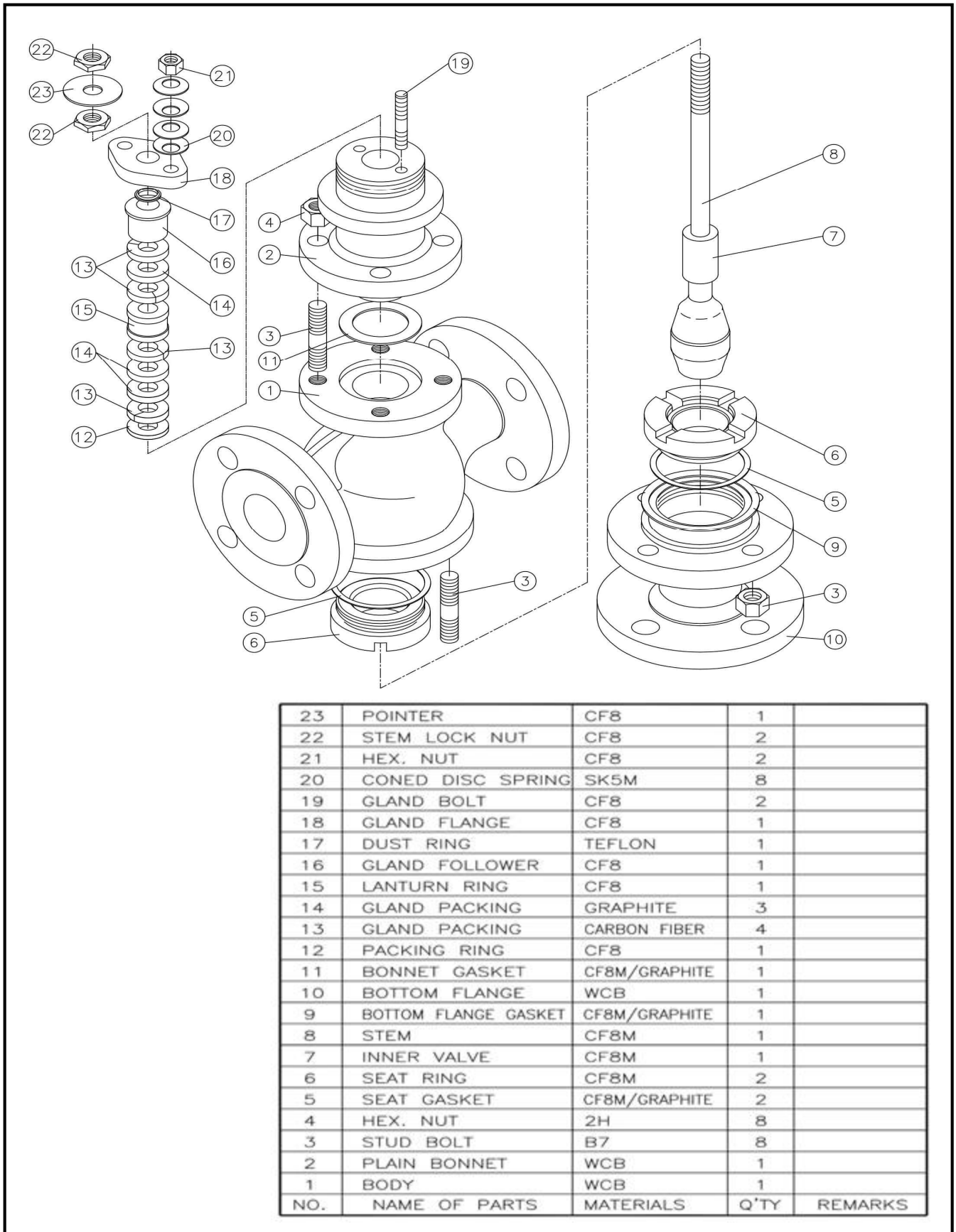

<FIG. 5-4> Body Disassembly and Assembly Diagram

## 6. Preventive Maintenance and Troubleshooting

### \* Note

Replace parts after inspection by referring to the Part Replacement Cycle Sheet in Section 5. For other parts, replace them to prevent damages to other devices when they show a wearing sign.

### 6.1 Troubleshooting

Table 6-1 shows some remedies to general problems that may occur at the site while using control valves. For more serious problems, transport the system to the factory.

Table 6-1

Problem	Solution
Leak from Stem Packing	<ol style="list-style-type: none"> <li>1. Fasten the packing flange. Check for leaking.</li> <li>2. If you suspect any damage to the stem, go to item no.3 Otherwise, replace packing and the O-rings of gland flange after taking all safety precautions at the site.</li> <li>3. Disassemble the valve. Visually inspect the stem. Check whether the plug components are damaged, and replace them if necessary. Also, replace the gland packing.</li> </ol>
Excessive internal leak when the valve is closed	<ol style="list-style-type: none"> <li>1. Check the air pressure supplied to the valve.</li> <li>2. When the valve is closed               <ul style="list-style-type: none"> <li>- Check whether the output pressure gauge scale of the positioner is identical to the set pressure (4.0 kg/cm<sup>2</sup>) of the filter regulator (Direct Action).</li> <li>- Check whether the output pressure gauge scale of the positioner is at zero (Reverse Action).</li> </ul> </li> <li>3. Readjust the stroke so that the valve will be closed securely, and then reassemble the clamp. (For reverse action, perform this after supplying 2.0 kg/cm<sup>2</sup> of air to the actuator.)</li> </ol>
Leak from Bonnet	<ol style="list-style-type: none"> <li>1. Remove line pressure and fasten the bonnet.</li> <li>2. Disassemble the valve and check the bonnet gasket.</li> </ol>

Problem	Solution
When the plug does not move	<ol style="list-style-type: none"> <li>1. Check the air pressure supplied to the valve and then check the condition of the filter regulator.</li> <li>2. Check the operations of accessories such as volume booster, solenoid valve and air operated valve.</li> <li>3. Disassemble the valve and check whether there are any foreign substances in the plug, cage (guide) and seat.</li> <li>4. Check the design temperature and actual line temperature.</li> <li>5. Remove the actuator and try to operate the actuator only.</li> </ol>
When the valve does not follow input signals from positioner	<ol style="list-style-type: none"> <li>1. Check the air pressure supplied to the valve.</li> <li>2. Check the calibration and operation of positioner.</li> <li>3. Apply a proper air pressure to the actuator to see whether it works properly or leaks. (If it leaks, fasten the diaphragm cover bolts.)</li> <li>4. Check whether the feedback lever of the positioner is loose.</li> </ol>
The valve flow is low.	<ol style="list-style-type: none"> <li>1. Check pressure at the entrance and exit of the valve.</li> <li>2. Visually check whether the valve responds to signals.</li> <li>3. Check whether the valve operates with the maximum stroke.</li> <li>4. Recalibrate if the maximum stroke is not reached.</li> </ol>
The stroke time is delayed.	<ol style="list-style-type: none"> <li>1. Check the air pressure supplied to the valve.</li> <li>2. Check the pressure of the filter regulator. Clean the nozzle of the positioner.</li> <li>3. Check the adjustment of accessories such as booster solenoid.</li> </ol>
Overshoot and Hunting	<ol style="list-style-type: none"> <li>1. Check the air pressure supplied to the valve.</li> <li>2. Check the calibration of positioner.</li> <li>3. Check whether the adjustment of booster is too sensitive.</li> <li>4. Check whether the packing friction is strong.</li> </ol>