

Butterfly Valve



Contents

1. General	2
1.1 Introduction to Valves.....	2
1.2 Valve Structure.....	3
2. Storage	3
3. Installation	4
4. Operation	9
4.1 Inspections before Operation.....	9
5. Maintenance and Repair	10
5.1 General	11
5.2 Disassembly and Assembly of Valve Body and Actuator	11
5.2.1 Disassembly	11
5.2.2 Valve Assembly.....	12
5.3 Disassembly and Assembly of Actuator.....	12
5.4 Disassembly and Assembly of Body	13
5.4.1 Disassembly	13
5.2.2 Assembly.....	13
6. Preventive Maintenance and Troubleshooting	18
6.1 Troubleshooting.....	18

1. General

1.1 Introduction to Valves

- A) The butterfly valve has been designed for the requirements and applications of piping. As flow rate is effectively controlled, it has less cavitation, noise, corrosion, or vibration relatively.
- B) The most important feature of the butterfly valve is its body that has been manufactured in appropriate sizes to meet the requirements of piping. It consists of a body that includes a disc to control flow speed, a seat ring, a bonnet, and an actuator.
- C) The butterfly valve is designed for easy maintenance.
- D) The butterfly valve boasts a long life span and has few faults. To use the system to its full life span, you should install it correctly according to the manual and maintain it according to the prescribed procedures while using it.

☀ Recommendations

Engineer who has professional assembly capabilities are required to maintain Butterfly valves. Therefore, it is more economical to request repairs of the valves to Komoto. As the valves repaired by Komoto are thoroughly tested and warranted, you are recommended to entrust Komoto with repairs.

To avoid possible injury to personnel or damage to valve parts, WARNING and CAUTION notes must be strictly followed. Modifying this product, substituting non-factory parts or using maintenance procedures other than outlined could drastically affect performance, be hazardous to personnel and equipment and may void existing warranties.

1.2 Valve Structure

A) There are largely two types of butterfly valve: soft seat and metal seat. <See FIG. 1-1, 1-2, 5-4>

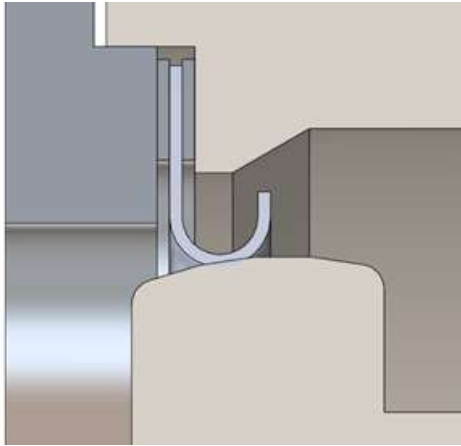

<FIG. 1-1> Metal Seat

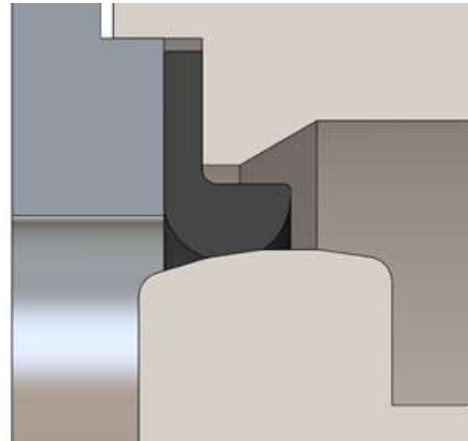

<FIG. 1-2> Soft Seat

2. Storage

- A) Do not throw, drop, trip or drag butterfly valves when transporting them.
- B) Keep all parts of the butterfly valve in a well-ventilated place protected from fire, rain and wind.
Store the valve at a temperature between - 29°C (-20°F) and 48°C (120°F).
The storage area must be protected from flooding.
- C) Operate the elastomer (rubber) of the pneumatic actuator at least once every six months to prevent their functional degeneration. Operate it to the full stroke even under general operation conditions at least three times a month.
- D) Do not remove the flange cap attached to the flange surface to prevent foreign substances from penetrating into the system until valves are installed on the line.

3. Installation

Like any other valves, the butterfly valve must be installed carefully at first according to the following cautions to use it for many years without malfunction.

- A) Remove the flange cap and check whether there are any foreign substances in the body. If you find foreign substances, remove them before starting installation.
- B) As cast steel products are processed with rust preventive oil before shipping to prevent corrosion, remove the rust preventive oil from the pipes before installing them on the line.
- C) Blow off all foreign substances including welding chips in the pipes before starting installation.

- Warning -

To prevent damages to disc and seat, you must blow out (flashing) foreign substances such as weld beads, scales and chips from the pipeline according to the prescriptions before installing the butterfly valve.

- D) Install valves in the direction of arrow marked on the body.
- E) When assembling the flange-type valve, you should use a specified gasket, and install it in parallel with the other flange. Also, you are recommended to fasten the bolts in several parts in a balanced manner sequentially in diagonal direction. <See FIG. 3-1>

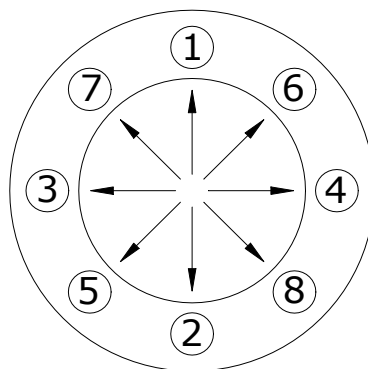

<FIG. 3-1> Procedure for Fastening Flange Bolts

F) Install the valve at right angle to the ground as much as possible. If this is impossible, attach a support to the valve before installing it. <See FIG. 3-2, 3-3>

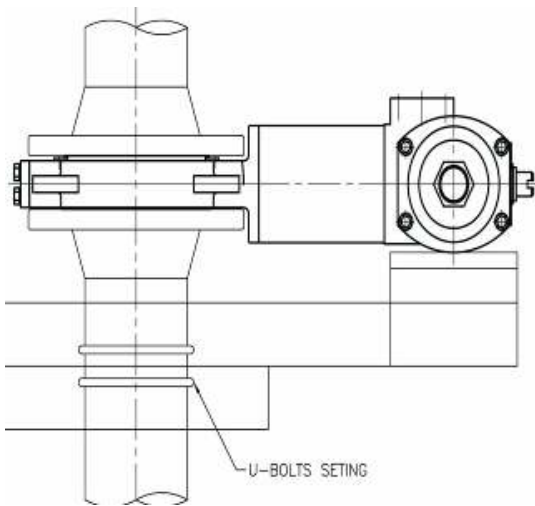

<FIG. 3-2> Installing Support

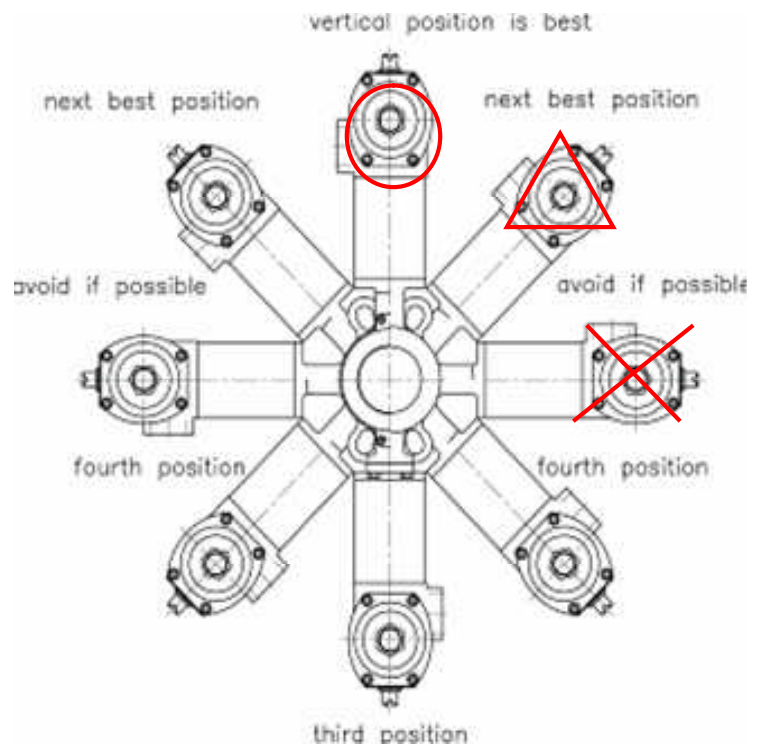

<FIG. 3-3> Installation Location of Actuator

☀ Cautions

- ① Avoid horizontal piping if possible because it may adversely affect the function and performance of valves during operation.
- ② When moving butterfly valves, you should handle them carefully so that the components and air piping will not be damaged. Otherwise, the electronic and electric parts such as solenoid valve, positioner, and limit switch may get damaged or the valve travel may change.
- ③ Be careful not to damage the sealing surface of valve flange.
- ④ Apply thermal insulation as needed, but do not apply thermal insulation to the cooling fin and extensions.

G) A minimum space is required for maintenance of the valve installation area. <See FIG. 3-4> In addition, a space for manual operation is required if a manual hand wheel has been installed.

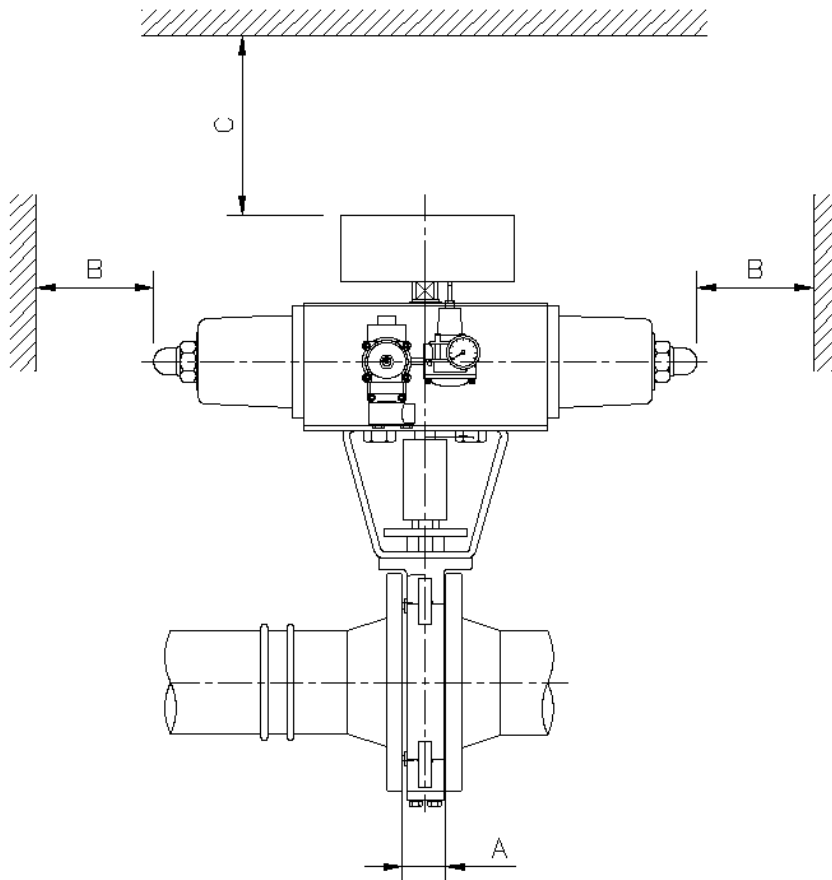

<FIG. 3-4> Space required for control valve installation

- ☞ A: Face-to-Face Dimension
- B: Minimum distance from obstacles (Approx. 30 cm)
- C: Space for removing the actuator (Approx. 40 cm)

H) Install a bypass line for valve maintenance. <See FIG. 3-5>

Note

When the control valve has a problem, you may have to close the block valve and open the bypass valve to adjust flow. Therefore, use a control valve that has the feature to adjust flow by opening the bypass valve. Moreover, it is ideal to choose the same flow characteristics and size as those of control valve. FIG. 3-6 illustrates an example of ideal control valve installation recommended by Komoto.

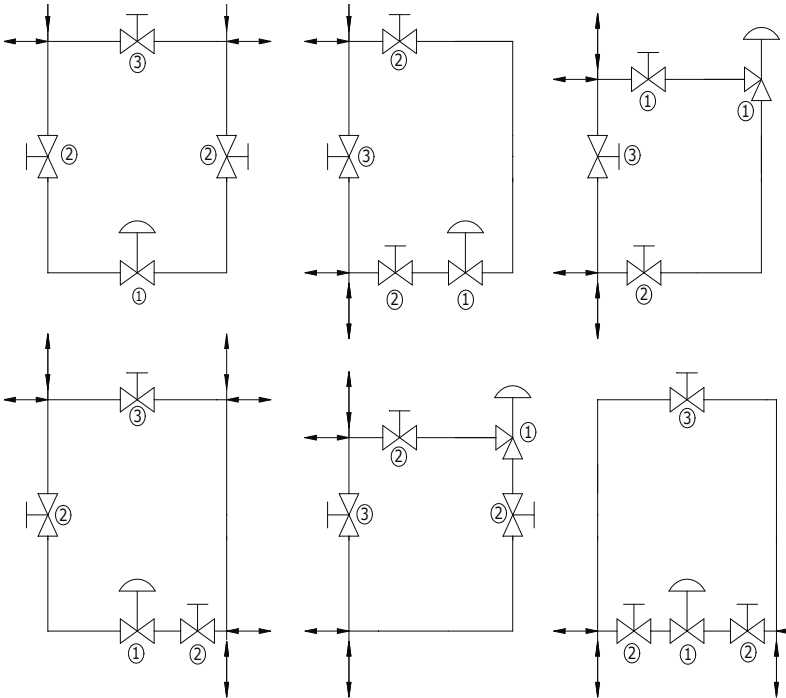

<FIG. 3-5> Example of Control Valve Installation

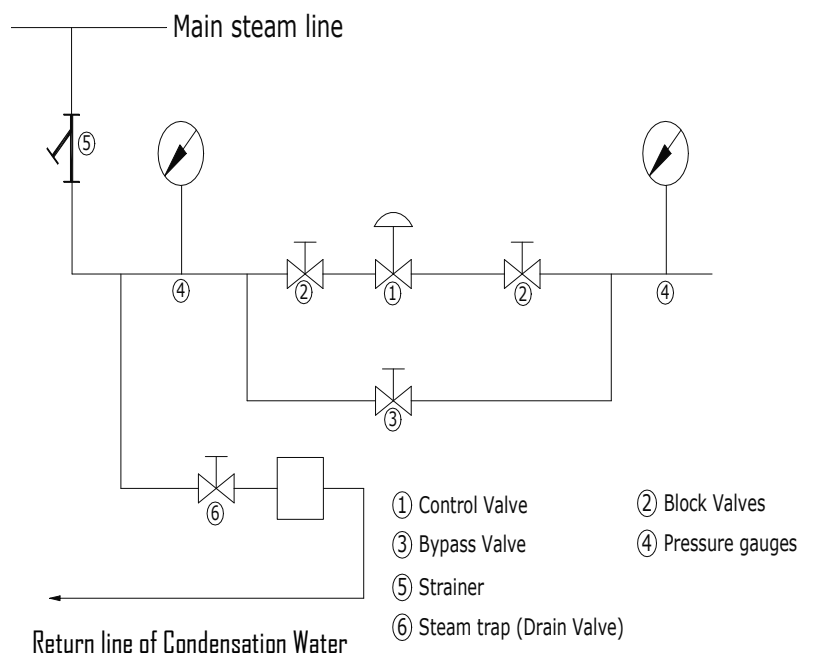

<FIG. 3-6> Example of Control Valve Installation Recommended by Komoto

☀ Note

To maintain a constant pressure at the entrance for all tracks of the valve, the straight pipe length at the valve entrance must be at least 10 to 20 times the pipe diameter. For the fluid to maintain the specified pressure after passing the valve and to prevent noise or vibration by turbulent flow, the straight pipe length at the valve exit must be at least 3 to 5 times the pipe diameter. Straight piping at the entrance and exit allows the preservation of accurate operation status by enabling accurate measurement of the pressure at the entrance and exit. <See FIG 3-7>

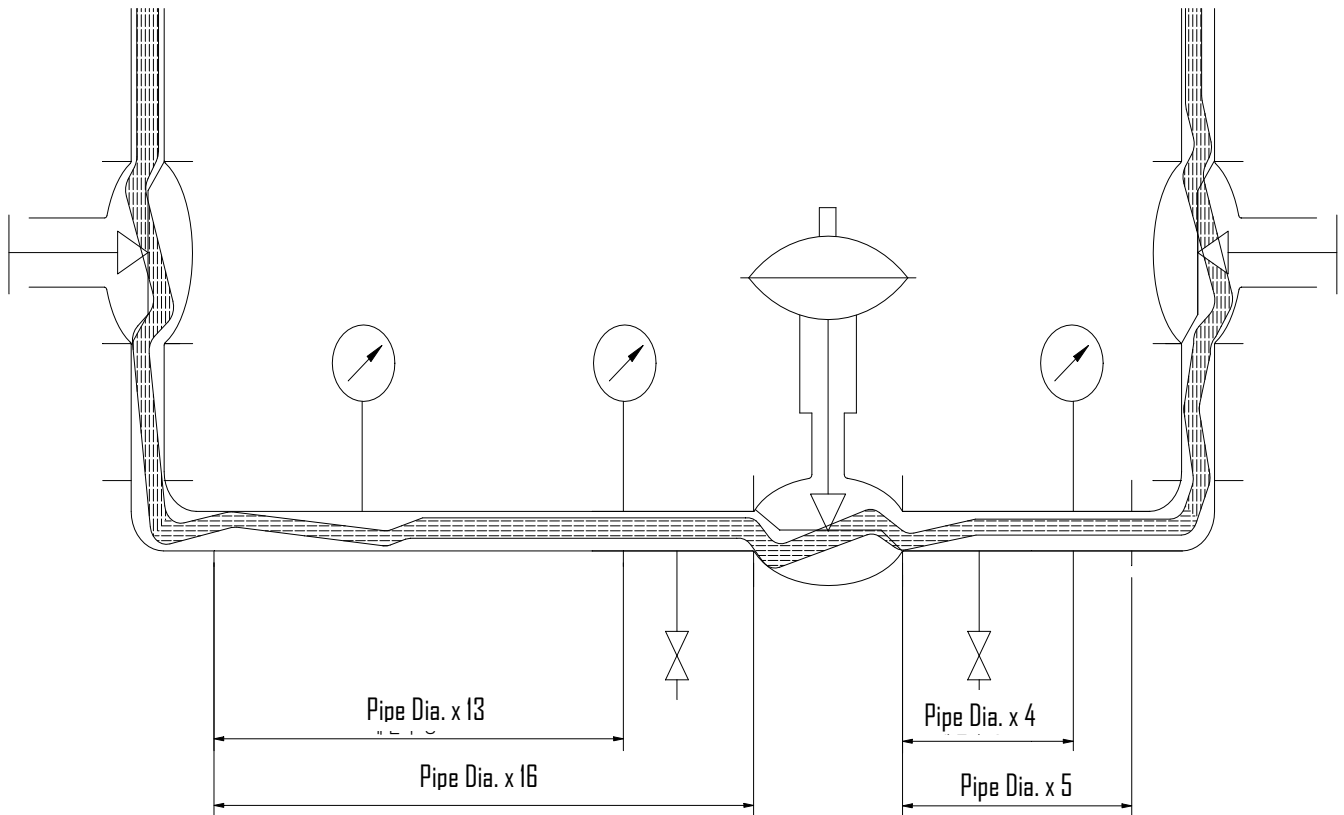

<FIG. 3-7> Minimum straight pipe length for valve performance and pressure measurement

4. Operation

4.1 Inspections before Operation

- ① Check whether there is any leak from all connections including the air pipe connections.
- ② To check whether there is any leak from gland packing and gaskets, apply a pressure to the pipeline. If any leak is detected, remove pressure from the pipeline and fasten the gland flange nut.
- ③ Check whether there are any loose nuts (clamps) at the valve stem and the spindle of the actuator.
- ④ Check whether there is any short circuit in the electric signal system.
- ⑤ Check whether the attached manual hand wheel is at the Neutral position.
- ⑥ Check whether the system operates accurately and flexibly according to the signals from the controller.
- ⑦ When raising the temperature or pressure, do it slowly. Never raise the temperature or pressure quickly.
- ⑧ Check whether the air pressure required for valve operation is accurately set (specified on the name plate).
 - i) Diaphragm Actuator: 4.0 kg/cm²
 - ii) Cylinder Actuator: 5.0 kg/cm²
- ⑨ Electrical devices such as positioner, limit S/W, solenoid V/V are attached to an control valve. Even if the manufacturer has adjusted them, the tubing may be bent or the valve stem's position become incorrect due to a shock during transportation or careless handling during assembly. Therefore, it is recommended to readjust the valve during the test run.

- Warning -

- ① Remove air pressure from the actuator before using the manual hand wheel. If you use the hand wheel without removing air pressure, it may not work normally and its weak part may get damaged by overstrain.
- ② If the manual hand wheel is not at the Neutral position during control operation, it may not work normally and its weak part may get damaged.
- ③ If you use a pressure higher than the specified pressure on the name plate, the rubber and O-rings of the actuator may be damaged and cause operation problems.

5. Maintenance and Repair

*** Regular Inspection**

Repair and inspect as described below. If any malfunction occurs, take appropriate measures according to the preventive maintenance procedures and troubleshooting in Chapter 6. Also, disassemble and inspect the system during the regular overhaul period, and replace parts if necessary.

*** Recommendations**

① The life span of the valve can increase if you replace parts according to their replacement cycles. Refer to the Part Replacement Cycle Sheet shown below.

Part Replacement Cycle Sheet		
Item Name	Replacement Cycle	Others
Packing	2 years	
Gasket	2 years	
Seat Ring		Replace after inspection according to the fluid conditions and used environment.

*** Irregular Inspections**

- A) Are there abnormal noise, vibration or hunting?
- B) Does the fluid leak from the valve?
- C) Are there any loose bolts and nuts?

5.1 General

- Warning -

1. To prevent human injuries and damages to control system, close the block valve, remove instrument air and signals from the valve and open the bypass valve to switch over the pressure from the line to the bypass. Then slowly unfasten the bolts from the pipe until the internal pressure of the body is completely released and remove the valve before disassembling the actuator.
2. Keep hands, hair and clothing away from seat and port when operating valve. Failure to do so could cause serious injury.

- ♣ Prepare gland packing, gaskets (bonnet) and O-rings as required. (Do not reuse parts that have been used.)

5.2 Disassembly and Assembly of Valve Body and Actuator

5.2.1 Disassembly

※ Note

- Mark important parts to assemble them to their original position during assembly.

◆ Valve Disassembly Procedure <See FIG. 5-1>

Disassemble in the sequence of Diaphragm Actuator Type and Cylinder Actuator Type ① → ②.

- ① Remove all accessories including positioner from actuator.
- ② Unfasten the yoke bolt and remove actuator and body.

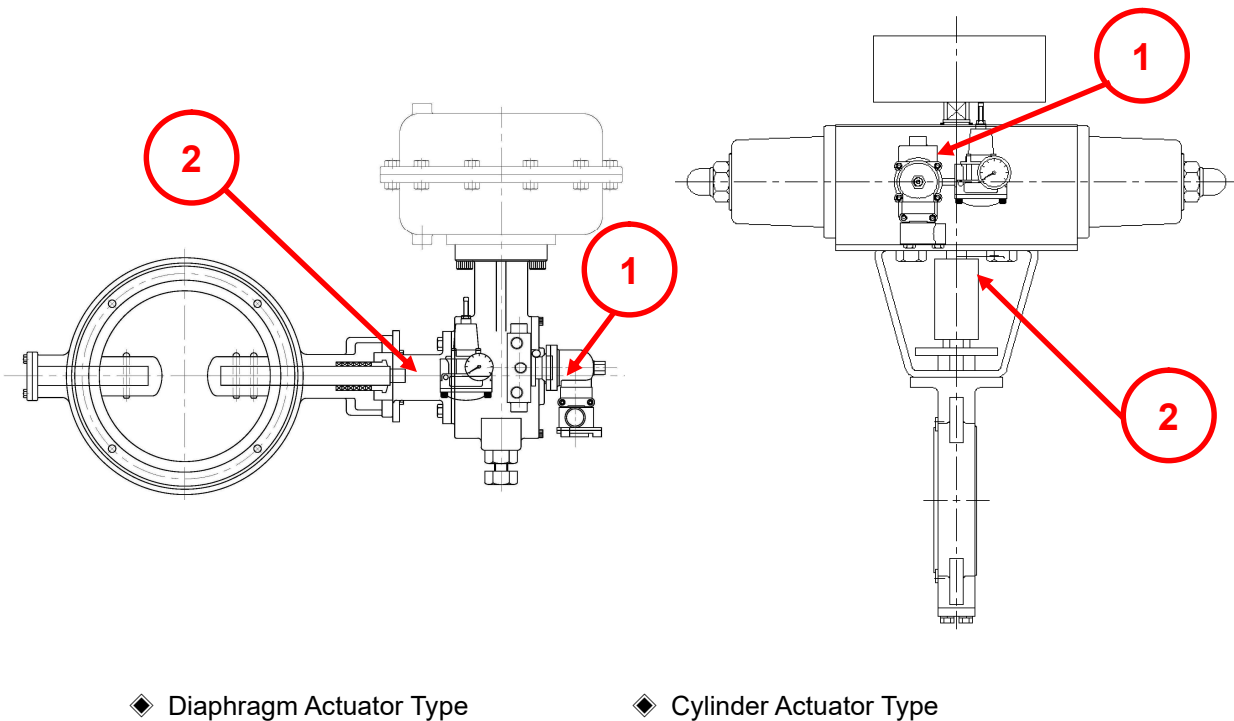

<FIG. 5-1> Disassembly Diagram for Actuator and Body

5.2.2 Valve Assembly

- ① Assemble in the reverse sequence of the disassembly.
- ② Reconnect accessories including positioner. Then perform calibration again.

5.3 Disassembly and Assembly of Actuator

- ◆ Do not disassemble or assemble the actuator on your own at the site, but contact our technical department.

- Warning -

The components of a spring return type actuator are pressed down by a spring. Take general safety measures and disassemble correctly. Otherwise, injuries and damages may result.

5.4 Disassembly and Assembly of Body

5.4.1 Disassembly <See Fig. 5-4>

- ① As described in Section 5, Clause 5.2, remove the actuator from the valve while taking care not to damage accessories and pipes by the valve body components.
- ② Unfasten bolts from the retainer (17).
- ③ Remove the retainer (11) from the body.
- ④ Remove plug/seat, valve gaskets, other components from the body.
- ⑤ Remove packing from the packing box using hook.
- ⑥ Clean each part and check them for any damage. Prepare available parts for future repair.

- Warning -

To replace packing, remove packing while taking care not to damage the internal surface of the packing box.

• Inspection after Disassembly

- i) Are there any damages to the seat ring contact surface, V-balls, seat, or stem?
- ii) Are there any damages to the body sealing surface?
- iii) Are there any damages to the gasket and gland packing?

5.4.2 Assembly

※ Recommendations

Always inspect and replace worn-out parts before starting reassembly. You are recommended to always replace soft products such as gland packing and gasket before reassembling.

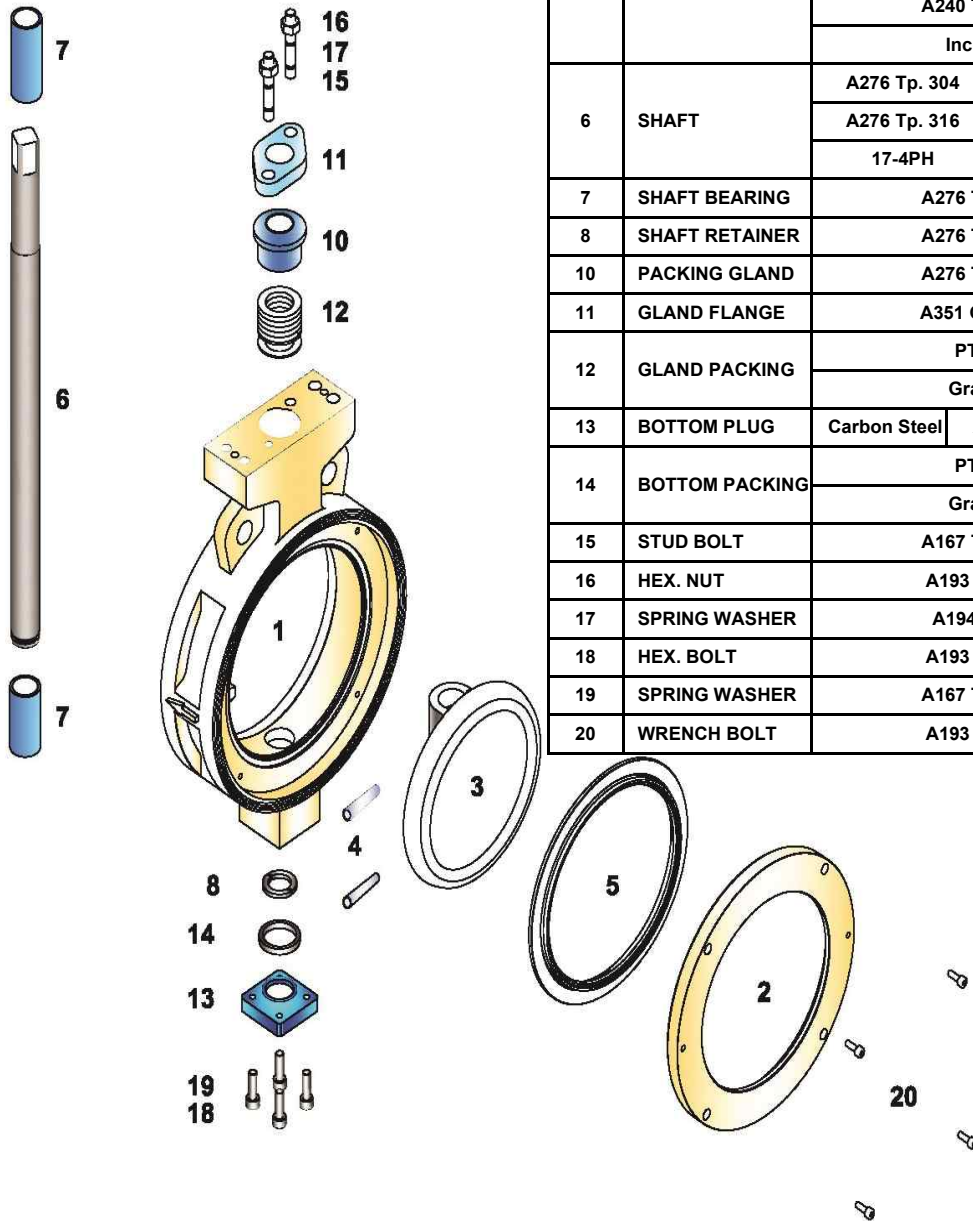

PART NO.	DESCRIPTION	MATERIAL		REMARKS
		CARBON STEEL	STAINLESS STEEL	
1	BODY	A216 Gr. WCB	A351 Gr. CF8	
			A351 Gr. CF8M	
2	INSERT RING	Carbon Steel	A240 Tp. 304	
			A240 Tp. 316	
3	DISC	A351 Gr. CF8		
		A351 Gr. CF8M		
4	DISC PIN	A276 Tp. 316		
5	SEAT	PTFE		
		R.TFE		
		A240 Tp. 304		
		A240 Tp. 316		
6	SHAFT	A276 Tp. 304	A276 Tp. 304	
		A276 Tp. 316	A276 Tp. 316	
		17-4PH	Duplex	
		Inconel		
7	SHAFT BEARING	A276 Tp. 316		
8	SHAFT RETAINER	A276 Tp. 316		
10	PACKING GLAND	A276 Tp. 316		
11	GLAND FLANGE	A351 Gr. CF8		
12	GLAND PACKING	PTFE		
		Grafoil		
13	BOTTOM PLUG	Carbon Steel	A351 Gr. CF8M	
14	BOTTOM PACKING	PTFE		
		Grafoil		
15	STUD BOLT	A167 Tp. 304		
16	HEX. NUT	A193 Gr. B8		
17	SPRING WASHER	A194 Gr. 8		
18	HEX. BOLT	A193 Gr. B8		
19	SPRING WASHER	A167 Tp. 304		
20	WRENCH BOLT	A193 Gr. B8		

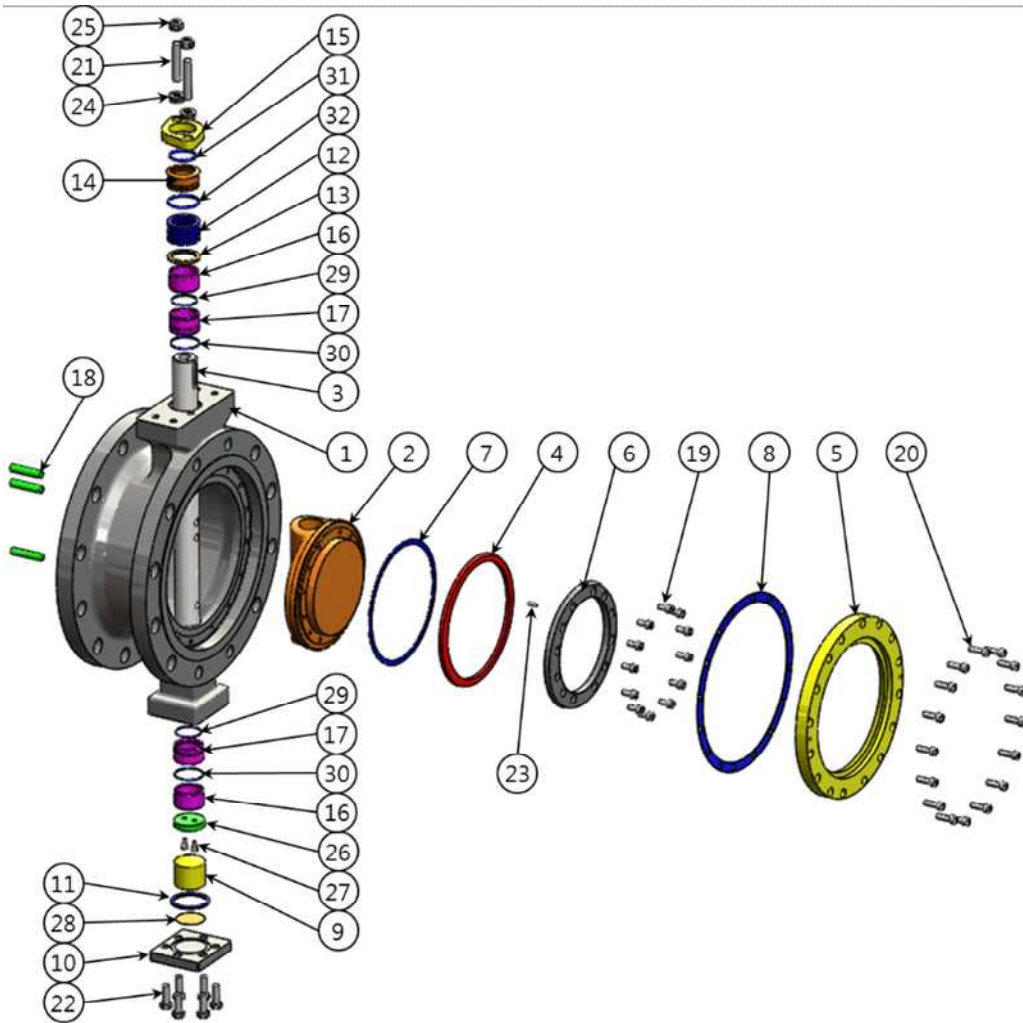

Materials of Construction.

ITEM	QTY	DESCRIPTION	CARBON STEEL	STAINLESS STEEL	
			Up to 800°F (421°C)	Up to 600°F (316°C)	Up to 800°F (421°C)
1	1	Body	A216WCB	A 351 Gr. CF8/ CF8M	A 351 Gr. CF8 / CF8M
2	1	Disc	A 216 Gr. WCB nickel plated121	A 351 Gr. CF8 / CF8M or A182 F316	A351 Gr.CF8 / CF8M or A182 F316
3	1	Spindle	A479 Gr.410	Type 630 ASTM 564	A638 Type 660,
4	1	Disc seat	Stainless steel	Stainless steel	Stainless steel
5	1	Body seat	Stainless steel + Graphite	Stainless steel + Graphite	Stainless steel + Graphite
6	1	Disc seat retainer	Stainless steel	Stainless steel	Stainless steel
7	1	Disc seat gasket	Graphite	Graphite	Graphite
8	1	Body seat gasket	Graphite	Graphite	Graphite
9	1	Thrust pad	Stainless steel	Stainless steel	Stainless steel

10	1	Bottom cover	WCB or A 105	CF8/ CF8M or F316	CF8/ CF8M or F316
11	1	Bottom cover gasket	SS 347 +Graphite	SS 347 +Graphite	SS 347 +Graphite
12	5	Packing	Graphite	Graphite	Graphite
13	1	Packing ring	Stainless steel	Stainless steel	Stainless steel
14	1	Gland follower	Stainless steel	Stainless steel	Stainless steel
15	2	Gland flange	Carbon steel	Stainless steel	Stainless steel
16	Set	Bush	Stainless steel (Nitrided)	Stainless steel (chrome plated)	Stainless steel (chrome plated)
17	Set	Dust bush	Stainless steel (Nitrided)	Stainless steel (chrome plated)	Stainless steel (chrome plated)
18	Set	Stem pin	A479 Gr.410	Type 630 ASTM 564 M	A 638 Type 660
19	Set	Disc seat bolt	Stainless steel	Stainless steel	Stainless steel
20	Set	Body seat bolt	Stainless steel	Stainless steel	Stainless steel
21	Set	Gland bolt	A193Gr.B7	A193 Gr. B8	A193 Gr. B8
22	Set	Bottom cover bolt	A193 Gr. B8M	A193 Gr. B8	A193 Gr. B8
23	1	Disc pin	A479 Gr.410	Type 630 ASTM 564	Type 630 ASTM 564
24	Set	Conical washer	Stainless steel	Stainless steel	Stainless steel
25	Set	Gland nut	A194Gr.2H	A194 Gr.8	A194 Gr.8
26		Spindle lock pad	A479 Gr.410	Type 630 ASTM 564	Type 630 ASTM 564
27		Spindle lock bolt	A193Gr.B7	A193 Gr. B8	A193 Gr. B8
28		Bottom sheet	A479 Gr.410	Stainless steel	Stainless steel
29		Bush o-ring (in)	NBR, FKM	NBR, FKM	NBR, FKM
30		Bush o-ring (Out)	NBR, FKM	NBR, FKM	NBR, FKM
31		Gland follow o-ring (in)	NBR, Silicon	NBR, Silicon	NBR, Silicon
32		Gland follow o-ring (out)	NBR, FKM	NBR, FKM	NBR, FKM

FIG. 5-5> Body Assembly Diagram

◆ Body Assembly Procedure

* Always check cleanness and the condition of packing before assembly.

1) Connect the Du bushes to the top and bottom of the body.

* Caution: Take care not to damage the packing.

2) Place the disc at the center of the body using a jig.

3) Connect the thrust bearing disc to the body bottom.

* Caution: If this is omitted, the torque may rise by being loaded by operation.

4) Insert the stem to the body and disc. At this time, take care not to move the key position.

* Caution: - Assemble from the bottom first as there is an elevation that plays the role of stopper at the bottom.

- Take care not to make scratches on the stem that is contacted with packing during assembly.

5) Connect the thrust bearing disc.

6) Connect the bottom gasket to the bottom cover.

* Note: You may apply grease to the gasket for easy work.

7) Connect the bottom cover with a gasket to the body.

* Caution: Make sure that there is a thrust bearing disc in it.

The stem should not move after connecting the cover.

8) Assemble the packing ring.

9) Assemble packing.

10) Apply grease to the gland follower O-ring.

11) Connect the O-ring to the gland follower.

* Caution: Take care not to make scars on the surface of O-rings.

12) Connect the gland flange and fasten bolts or stud bolts.

13) Check the fixing of the disc.

* Danger: As it is difficult to disassemble once the disc is fixed using a pin, check the distance between body and disc again.

14) Make a hole with a drill at the crossing between stem and disc.

* Caution: The front and rear surfaces of the disc must not be penetrated.

15) Insert a taper pin into the processed part and fix it with a hydraulic press.

16) Disconnect the jig and make sure that the disc is closed.

17) Insert the first seat ring gasket and the second seat ring. Then finally insert the seat ring gasket.

18) Connect the retainer and fasten the bolts.

6. Preventive Maintenance and Troubleshooting

* Note

Replace parts after inspection by referring to the Part Replacement Cycle Sheet in Section 5. For other parts, replace them to prevent damages to other devices when they show a wearing sign.

6.1 Troubleshooting

Table 6-1 shows some remedies to general problems that may occur at the site while using V-notch valves. For more serious problems, transport the system to the factory.

Table 6-1

Problem	Solution
Leak from Stem Packing	<ol style="list-style-type: none"> 1. Fasten the packing flange. Check for leaking. 2. If you suspect any damage to the stem, go to item no.3 Otherwise, replace packing after taking all safety precautions at the site. 3. Disassemble the valve. Visually inspect the stem. Check whether the plug components are damaged, and replace them if necessary. Also, replace the gland packing.
Excessive internal leak when the valve is closed (Seat)	<ol style="list-style-type: none"> 1. Check the air pressure supplied to the valve. 2. If you suspect any damage to disc or seat, go to item no.3 3. Disassemble the valve. Visually check disc and seat for damages. Replace them if any damage is found.
The stroke time is delayed.	<ol style="list-style-type: none"> 1. Check the air pressure supplied to the valve. 2. Check the pressure of the filter regulator. 3. Check the adjustment of accessories such as booster solenoid.
Leak from Bonnet	<ol style="list-style-type: none"> 1. Remove line pressure and fasten the bonnet. 2. Disassemble the valve and check the gasket.

Problem	Solution
The disc does not move	<ol style="list-style-type: none"> 1. Check the air pressure supplied to the valve and then check the condition of the filter regulator. 2. Check the operations of accessories such as solenoid valve and air operated valve. 3. Disassemble the valve and check whether there are any foreign substances in disc and seat. 4. Check the design temperature and actual line temperature. 5. Remove the actuator and try to operate the actuator only.
The valve does not respond to input signals.	<ol style="list-style-type: none"> 1. Check the air pressure supplied to the valve. 2. Check the voltage of the solenoid valve. 3. Apply a proper air pressure to the actuator to see whether it works properly or leaks. (If it leaks, fasten the cylinder cover bolts.)
The valve flow is low.	<ol style="list-style-type: none"> 1. Check pressure at the entrance and exit of the valve. 2. Visually check whether the valve responds to signals. 3. Check whether the valve operates with the maximum stroke.